

AIRSCRAPE®

Dust free and contact free Conveyor belt skirting



TECHNICAL DATA SHEET

MEASURES IN INCH

The AirScrape conveyor belt skirting system hovers close to contact free on the left and right side of the conveyor belt using the air suction generated by the material movement and the moving belt.

Due to the diagonal array of the AirScrape lamellas which creates an airflow towards the center of the conveyor belt, spillage and dust generation at transfer points and other critical areas in the conveyor chain are significantly reduced.

AirScrape – Conveyor belt skirting

- consists of low-wear polyurethane
- Lamellas made from Hardox / Stainless Steel
- consists of a right and a left design (2 m each)
- available in Large, Medium and Small version
- is mounted on the outer underside of the existing chute wall
- maintenance free, based on provision that application is used in accordance with the guidelines
- provides belt protection and close to no belt contact
- can be used for any belt speed
- in FDA approved material available
- can be made of nonflammable and antistatic material (polyurethane)

REQUIREMENT FOR THE USE OF AIRSCRAPE

The prerequisite for this is a transfer situation that corresponds to the state of technology. The conveyor belt has to run in the middle and should not sag in the loading area. This can be achieved by using suitable belt guides, more rollers or a transfer table. A partial straightening of the outer belt area by special measures (e. g. replacement of the rollers by sliding bar construction) is also conceivable.

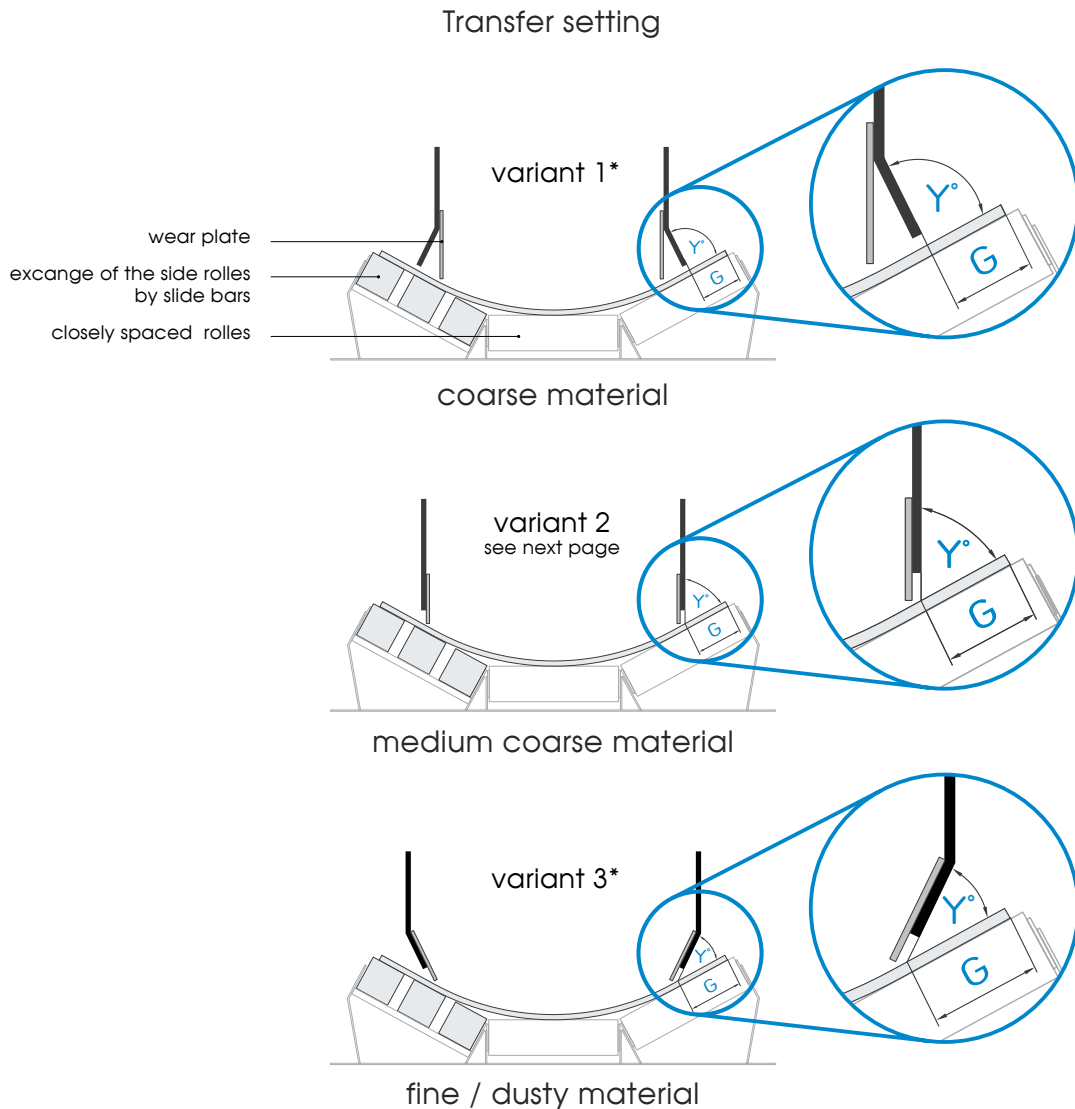

Y° = angle between mounting plate and conveyor belt

*consultation with ScrapeTec Trading GmbH



NOTE

AirScrape is not suitable for:

1. reversing belts
2. for conveyor belt inclines $> 15^\circ$, for inclines higher than 15 degrees please contact us for technical advice
3. in transfer situations where the main volumetric flow rate meets the side seal directly (special measures necessary)
4. Materials in the hardening / reaction process (e. g. pozzolanic materials and simultaneous addition of water to combat dust)

**ATTENTION**

The belt overlay must be permanent.
Belt overhang fluctuations must be taken into account.

AirScrape - LARGE**Hardox****Stainless Steel**Suitable for trough angle (X°) from 0° to 45° Belt overhang: $> 3.94''$ Free mounting area appx. $5.52'' - 6.70''$

Build-in dimensions (inch)

X°	H	G
0°	5.40	3.94
10°	5.48	4.06
15°	5.59	4.18
20°	5.75	4.33
25°	5.91	4.53
30°	6.11	4.77
35°	6.34	5.04
40°	6.58	5.32
45°	6.82	5.63

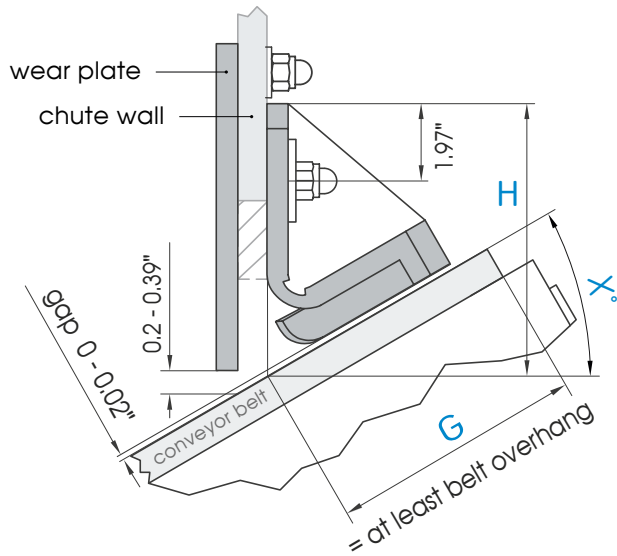
**AirScrape - MEDIUM****Hardox****Stainless Steel**Suitable for trough angle (X°) 0° to 45° Belt overhang: $> 3.15''$ Free mounting area appx. $4.72'' - 5.91''$

Build-in dimensions (inch)

X°	H	G
0°	4.73	3.15
10°	4.77	3.27
15°	4.85	3.39
20°	4.93	3.55
25°	5.08	3.74
30°	5.28	3.98
35°	5.52	4.26
40°	5.79	4.57
45°	6.11	4.93

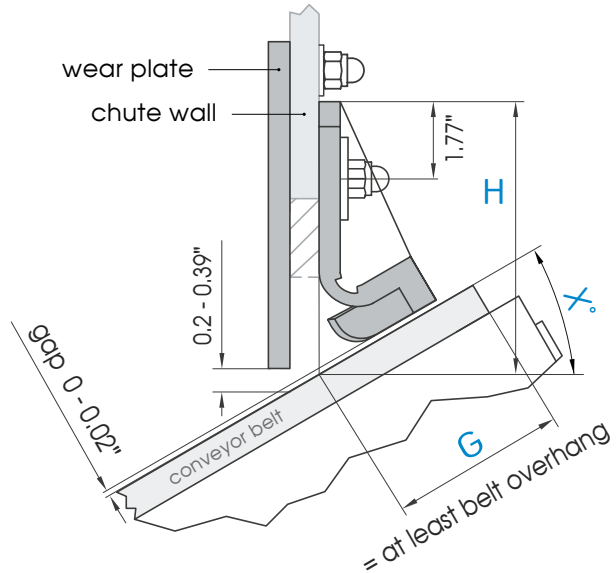
**AirScrape - SMALL****Hardox****Stainless Steel**Suitable for trough angle (X°) 0° to 45° Belt overhang: $> 2.17''$ Free mounting area appx. $4.33'' - 5.12''$

Build-in dimensions (inch)

X°	H	G
0°	4.33	2.17
10°	4.41	2.25
15°	4.53	2.36
20°	4.65	2.48
25°	4.77	2.60
30°	4.89	2.76
35°	5.04	2.92
40°	5.24	3.11
45°	5.48	3.35

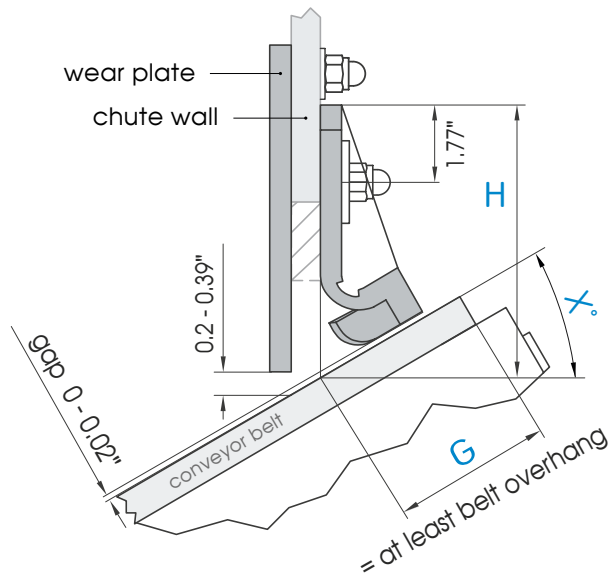

Ideal Sealing

(example: straight design)

Pre-sealing and AirScrape

This construction is mounted (starting with reference to direction of flow) with a 0.20" gap to the belt.

In the conveying direction, this gap dimension increases by 0.20" / 3.28'.

Length approx. 1.5 x belt width.

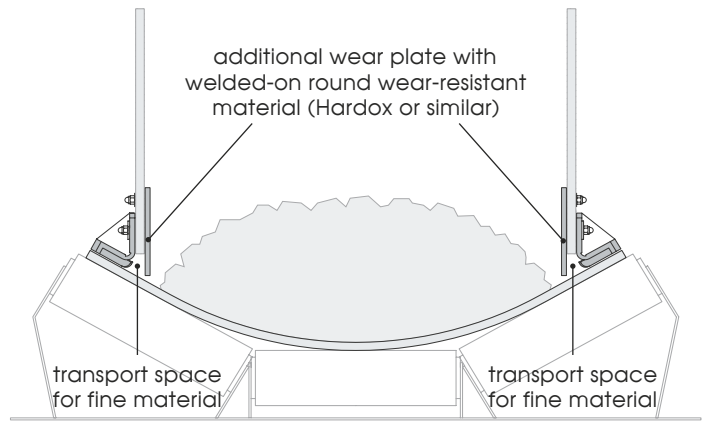

Off-center loading of conveyor belts is responsible for many consequential damages and problems

Material feed off-center:

- belt runs in the transfer area and side sealings lose their function,
- the belt misalignment is the result, because the material weight forces the belt into the lowest point of the conveyor belt trough,
- unloading onto the lower belt or belt edge damage can result,
- side sealings wear out quickly with the consequences of spillage and dust leakage,
- ...

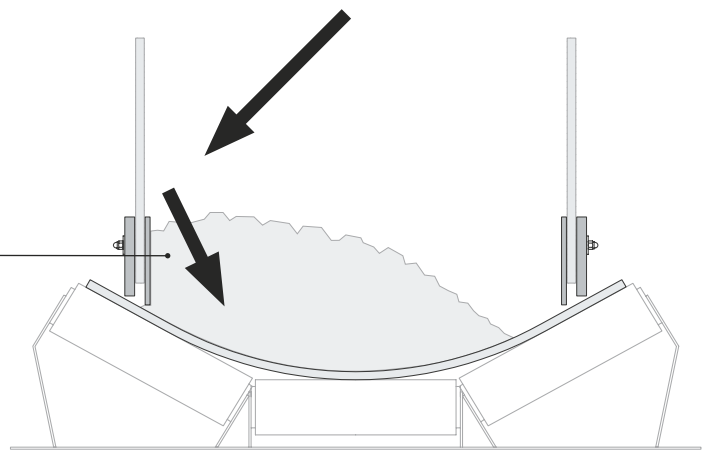

Improvement of the central loading of conveyor belts by using accumulation plates

(creation of a natural slope)

This construction starts (in terms of the conveying direction) wider and gets smaller in the conveying direction.

Length approx. 1.5 x belt width.

Installation width „B“ as a function of volumetric flow rate.

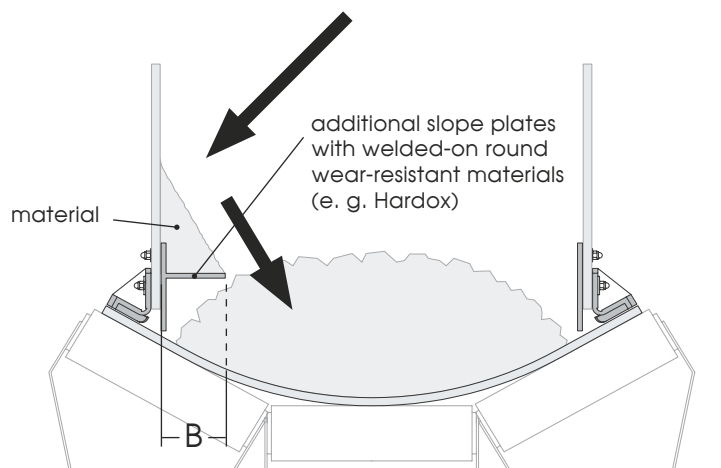

INSTRUCTIONS TO USE EXISTING MOUNTING SYSTEMS

For the installation and use of existing mounting systems notice the following:

The fastening bold (1) or any other attachments / clamping systems needs a distance $> 5.51''$ for AirScrape Large ($> 5.12''$ for AirScrape Medium and $> 4.72''$ for AirScrape Small) towards the belt surface (2).



IMPORTANT

The position of the clamp angle (3) needs a minimum of $1.97''$ distance towards the belt surface (4) and needs to be above the bending angle of the AirScrape.

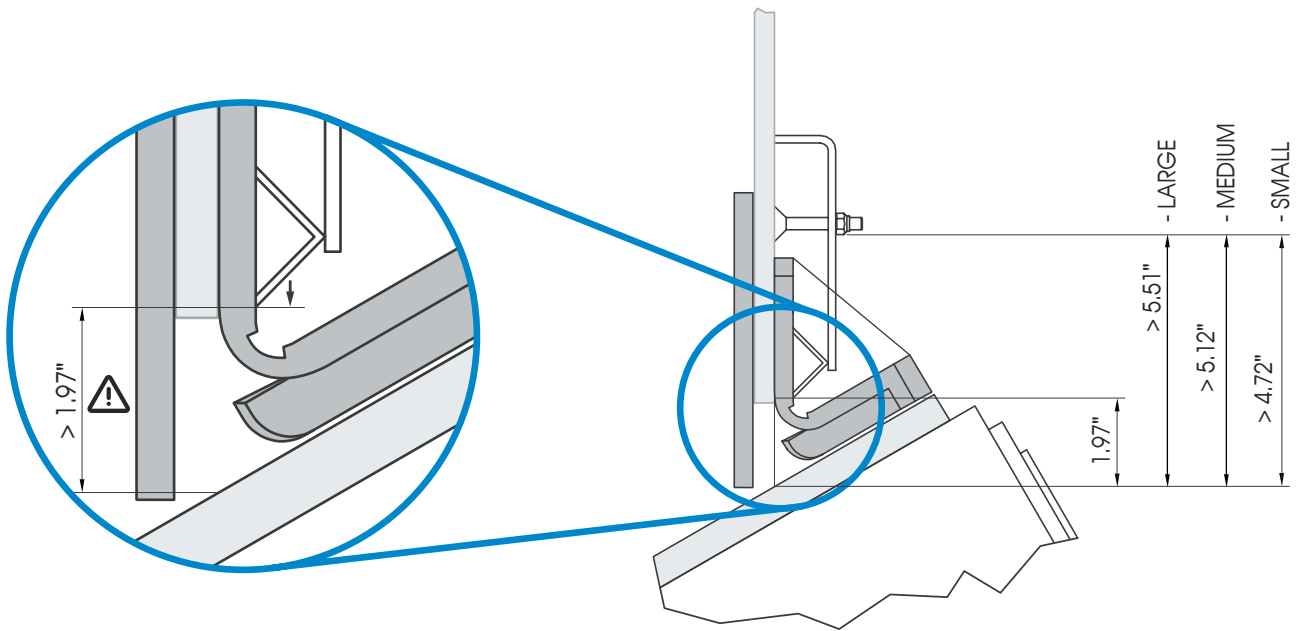

AirScrape LARGE

Distance between tensing bold (1) and belt surface (2) $> 5.51''$

AirScrape MEDIUM

Distance between tensing bold (1) and belt surface (2) $> 5.12''$

AirScrape SMALL

Distance between tensing bold (1) and belt surface (2) $> 4.72''$

ADAPTER SHEETS

For some applications, special adapter plates / sheets are necessary:

For example

- With a distance from the bottom of the chute wall and the belt surface of:
 - $> 3.15'' - 4.33''$ for AirScrape Large
 - $> 2.36'' - 3.94''$ for AirScrape Medium
 - $> 1.97'' - 3.15''$ for AirScrape Small
- if there is an existing screw-on option on the side wall it should / can be used for direct attachment of the system.

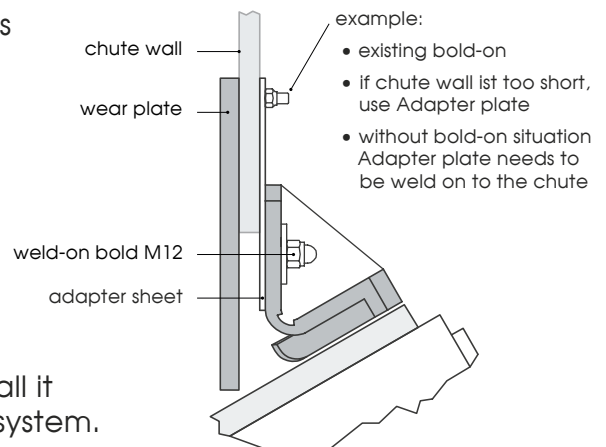

TECHNICAL DATA AIRSCRAPE

Carrier material, optional: Polyurethane - low-wear
 - non flammable and antistatic
 - FDA

Shore: Shore A 65 ± 5

Working temperature: -30° to $+85^{\circ}$ C

Lamella material: > 360 HB or stainless steel

System length: $6.56' \pm 0.39''$ right and left-hand side

More detailed information and special specifications are available on request.

OVERALL VIEW

